

DJI E300 Multirotor Propulsion System

User Manual v1.00

2013.11.20 Revision

Disclaimer

Read this disclaimer carefully before using this product. By using this product, you hereby agree to this disclaimer and signify that you have read them fully. DJI Innovations assumes no liability for damage(s) or injuries incurred directly or indirectly from the use of this product.

DJI is the registered trademark of DJI Innovations. Names of product, brand, etc., appearing in this manual are trademarks or registered trademarks of their respective owner companies. This product and manual are copyrighted by DJI Innovations with all rights reserved. No part of this product or manual shall be reproduced in any form without the prior written consent or authorization of DJI Innovations. No patent liability is assumed with respect to the use of the product or information contained herein.

Cautions

When flying, the fast rotating propellers will cause serious damage and injury. Therefore, please fly with a high safety consciousness.

1. Keep flying multi-rotor away from obstacles, human beings, high-voltage lines and so on.
2. Do not get close to or touch the working motors and propellers, which will cause serious injury.
3. Make sure there is no short or open circuit.
4. Check that the propellers and the motors are installed correctly and firmly before flight.
5. Check whether all parts of multi-rotor are in good condition before flight. Do not fly with old or broken parts.
6. Use DJI parts as much as possible.

If you have any problem you cannot solve, please contact your dealer or DJI customer service.

In the Box

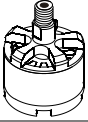
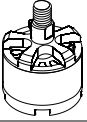
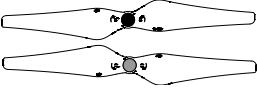
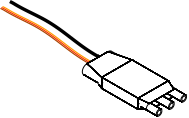
Motor(Clock-wise rotation)	Motor(Counter clock-wise rotation)	Propeller Pair
		
ESC	Accessories Pack	
	Power Hub, Screws (M2.5*Φ5*1.3*1) , Screws (M3*Φ4.9*6.8), Screws (M3*Φ5.5*4.5), Wrench for propeller fix, 2.0mm hexagonal wrench, Double side tape, etc.	

Tools Needed

Tool	Function
Electric Soldering Iron & Soldering Tin	Connects the ESCs' power cables to the power hub.

Soldering the ESC

1. Please solder the ESC to the power pads on the power hub as the figure shows. Make sure the welding spot is firmly attached on the power pads and no short circuit. Do not damage the protector of the red cable to avoid short circuit.
2. Connect the signal cable to your controller.
3. Connect the motor to the ESC. Make sure the rotation direction of each motor is the same as the way of defined rotation direction. If not, switch any of two cables that connecting the motor and the ESC to change its rotation direction.

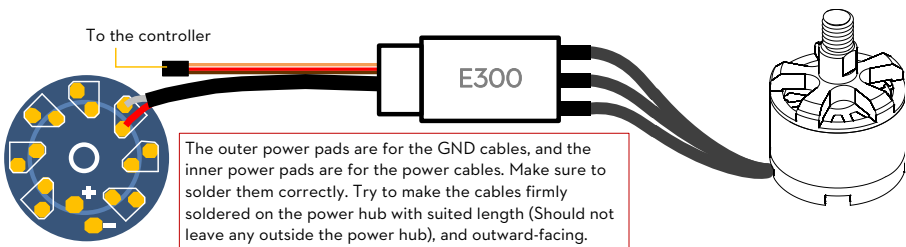







Make sure there is no short or open circuit.



It is recommended to solder a power connector on the power hub.

Assembling the Propellers

Propeller	Silver nut (9443)	Black nut (9443 R)
Diagram		
Assembly Location	 Motor(Counter clock-wise rotation)	 Motor(Clock-wise rotation)
Fastening/Un-fastening Instructions	 Lock: Tighten the propeller in this direction.	 Unlock: Remove the propeller in this direction.

1. Tighten the propellers by following the instructions. Propellers are self tightening during flight.
2. Keep the motor deadlocked in place and remove the propeller according to the instructions.



DO NOT use any thread locker on the threads.

Assembling the Motors

Assemble the motor to a frame arm according to the size of the assembly hole.

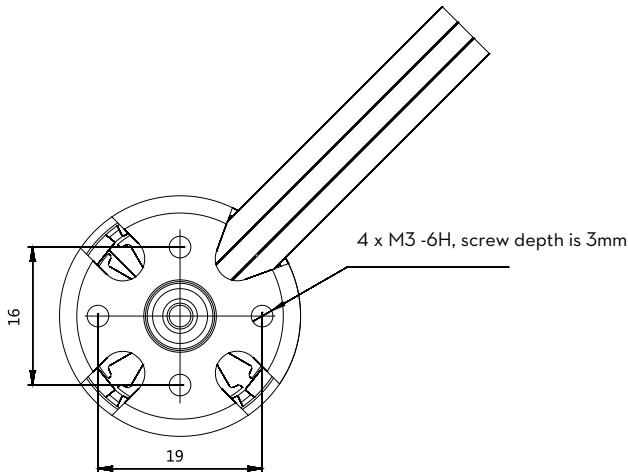

- (1) The screw hole is M3 with the depth of 3mm. Assemble them with appropriate screws.
- (2) Oversized screw may damage the motor.

ESC Sound Description

Normal	Description
1234567	Ready.
Abnormal	Description
BBBBBB...	Throttle stick is not at bottom.
B-----B-----B...	Input signal is abnormal.
BB---BB---BB---BB...	Input voltage is abnormal

 You can know the working status according to the sound of the ESC.

Specifications

Working Temperature	-5°C ~ 40°C
ESC	
Current	15A OPTO
Signal Frequency	30Hz-450Hz
Voltage	11.1V-14.8V
Battery	3S-4S LiPo
Motor	
Stator Size	22×12mm
KV	920rpm/V
Weight	50g
Propeller	
Diameter / Thread Pitch	24x11cm

Used Together with DJI Product

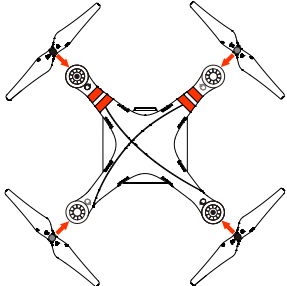
Product list and assembly diagram	
DJI F450	
DJI F550	
PHANTOM	
PHANTOM 2 VISION	

Used Together with PHANTOM 2 VISION